

Technical data sheet

Wall and support bracket AW 30 FT

Item number: 6419798



Medium-duty wall and support bracket with welded head plate.
Fastening of the bracket to the U support of width 400 mm or greater using a hexagonal bolt through both sides of the support. Please insert suitable spacers.



St

Steel

FT

Hot-dip galvanised

Master data

Item number	6419798
Type	AW 30 51 FT
Description 1	Wall and support bracket
Description 2	with welded head plate
Manufacturer	OBO
Dimension	B510mm
Colour	zinc
Material	Steel
Surface	Hot-dip galvanised
Surface standard	DIN EN ISO 1461
Smallest sales unit	1
Unit of quantity	Piece
Weight	129 kg
Weight unit	kg/100 pc.
CO2 Footprint (GWP) Cradle-to-Gate	3,0984 kg CO2e / 1 Piece

Technical data sheet

Wall and support bracket AW 30 FT

Item number: 6419798



Dimensions

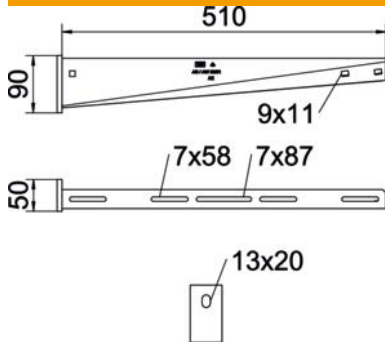

Length	50 mm
Width	510 mm
Height	90 mm
Dimension A	50 mm
Dimension B	510 mm
Dimension H	90 mm

Technical data

Version for	Wall and support bracket
EPD article	yes
F in kN	3 kN
Maintain electrical functions	no
Hole diameter	13 mm
Rustproof steel, pickled	no
Angle range, max.	90 mm
Angle range, min.	90 mm

Loads

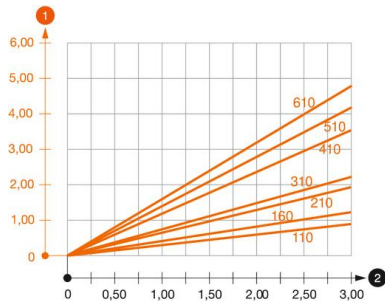

Load diagram, bracket, type AW 30

- 1** Bending of the bracket tip at permitted bracket load
- 2** Permitted bracket load in kN without man load
- Load curve with bracket lengths in mm

Technical data sheet

Wall and support bracket AW 30 FT

Item number: 6419798



Characteristic anchor load values for wall and support bracket AW 30

Wall fastening	Max. load [kN]
	Bracket width [mm]
Anchor type	<P>110</P>, <P>160</P>, <P>210</P>, <P>310</P>, <P>410</P>, <P>510</P>, <P>560</P>, <P>610</P>, <P>710</P>
BZ3 10x90/0-30	<P>3.00</P>, <P>2.10</P>, <P>-</P>, <P>-</P>, <P>-</P>, <P>-</P>
BZ3 12x110/0-35	<P>-</P>, <P>-</P>, <P>3.00</P>, <P>2.71</P>, <P>2.07</P>, <P>2.02</P>, <P>1.98</P>, <P>1.98</P>, <P>1.51</P>

Die angegebenen Werte basieren auf gerissenem Beton der Festigkeitsklasse C20/25. Die Einbaubedingungen der ETA-Zulassung (Dübel) sind zu beachten!

Load values for AW 30 on suspended support

Support	Max. total load F in kN
	Bracket length in mm
	<P>100</P>, <P>200</P>, <P>300</P>, <P>400</P>
US 3 K/ 20 - 60	<P>2.1</P>, <P>1.8</P>, <P>1.3</P>, <P>1.3</P>
US 3 K/ 70 - 120	<P>1.8</P>, <P>1.5</P>, <P>1.3</P>, <P>1.3</P>
US 5 K/ 20 - 60	<P>2.4</P>, <P>2.0</P>, <P>1.8</P>, <P>2.5</P>
US 5 K/ 70 - 120	<P>2.4</P>, <P>2.0</P>, <P>1.4</P>, <P>2.5</P>

