

# Technical data sheet

## Hot-dip galvanised steel bend, without thread

Item number: 2046818



90° bend with moulded sleeves, for electrical installation pipes according to EN 61386-1. With burr-free inner wall.



**St** Steel

**FT** Hot-dip galvanised

### Master data

Item number	2046818
Type	SBN25 FT
Description 1	Conduit plug-in bend
Description 2	without thread
Manufacturer	OBO
Dimension	Ø25mm
Material	Steel
Surface	Hot-dip galvanised
Surface standard	DIN EN ISO 1461
Smallest sales unit	25
Unit of quantity	Piece
Weight	24.4 kg
Weight unit	kg/100 pc.
CO2 Footprint (GWP) Cradle-to-Gate	0,8199 kg CO2e / 1 Piece

# Technical data sheet

## Hot-dip galvanised steel bend, without thread

Item number: 2046818



### Dimensions

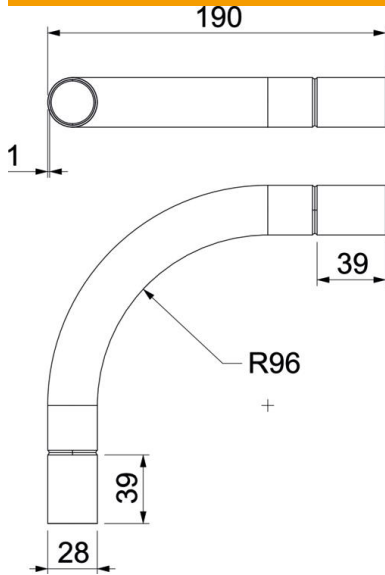

Dimension A	66.5 mm
Dimension B	191 mm
Dimension D	28 mm
Dimension d	25.5 mm
Dimension l	40 mm
Dimension m (mm)	M25
Dimension R	110 mm
Dimension t	1.2 mm

### Technical data

Version for	Connector
Flexible	no
For nominal pipe diameter	25 mm
Halogen-free	no
With inspection opening and lid	no
With sleeve	yes
Brushed surface	no
Polished surface	no
Permitted temperature range, max.	400 °C
Permitted temperature range, min.	-45 °C
Angle of the bend	90 °
Two-part	no