

Technical data sheet

TP support / wall and support bracket FS

Item number: 6364306



TP profile for use as lightweight support on horizontal concrete ceilings, on length 145–645 mm. Up to length 345 mm, the profile is used as a lightweight wall and support bracket.

In combination with the wall and support bracket, type TPSA/145, head reinforcement can be implemented with two fixing points. Important! If the profile is fixed directly to the ceiling or the profile is screwed together as head reinforcement, then, for reasons of stability, always use the spacer, type DS 4. For enmeshed profile mounting, use the truss-head bolt FRS 10/25 S. When mounting the profiles opposite each other (e.g. head reinforcement), use the hexagonal bolt, type SKS 10/60.



- St** Steel
- FS** Strip galvanized

Master data

Item number	6364306
Type	TPSA 345 FS
Description 1	TP wall and support bracket
Description 2	use as support and bracket
Manufacturer	OBO
Dimension	B345mm
Colour	zinc
Material	Steel
Surface	Strip galvanized
Surface standard	DIN EN 10346
Smallest sales unit	1
Unit of quantity	Piece
Weight	60 kg
Weight unit	kg/100 pc.
CO2 Footprint (GWP) Cradle-to-Gate	1,4016 kg CO2e / 1 Piece

Technical data sheet

TP support / wall and support bracket FS



Item number: 6364306

Dimensions

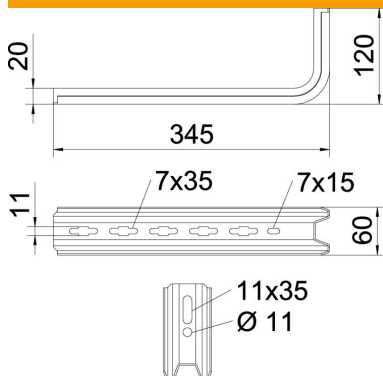

Length	345 mm
Width	60 mm
Height	120 mm
Dimension B	60 mm
Dimension H	120 mm
Dimension L	345 mm

Technical data

Version for	Wall and support bracket
F in kN	0.55 kN
Maintain electrical functions for width max.	no
for width min.	300 mm
Rustproof steel, pickled	300
	no

Loads

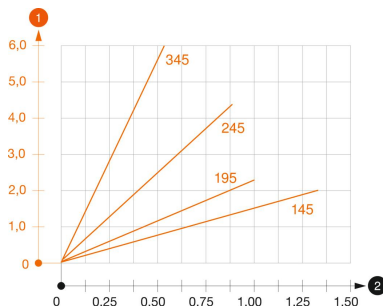

Load diagram, bracket, type TPSA

- 1 Bending of the bracket tip at permitted bracket load
- 2 Permitted bracket load in kN without man load
- Load curve with bracket lengths in mm

Characteristic anchor load values for TP bracket

Wall fastening	Max. load [kN]
	Bracket width [mm]
Anchor type	<TEXT><P>145</P></TEXT>, <TEXT><P>195</P></TEXT>, <TEXT><P>245</P></TEXT>, <TEXT><P>345</P></TEXT>
BZ3 10x90/0-30	<TEXT><P>1.3</P></TEXT>, <TEXT><P>0.93</P></TEXT>, <TEXT><P>0.60</P></TEXT>, <TEXT><P>0.55</P></TEXT>

Max. Belastung Fges. = Kabelgewicht + Kabelrinne + Ausleger. Die angegebenen Werte basieren auf ungerissenem Beton der Festigkeitsklasse C20/25. Die Einbaubedingungen der DIBt-Zulassung (Dübel) sind zu beachten!